

GENERAL DATA

CRANE CAPACITY	30 ton at 10 feet (27t at 3.0m)
BOOM	3-section, 32'8" – 80'0" (9.9 m – 24.4 m)
DIMENSION	
Overall Length	41'1" (12.52 m)
Overall Width (tracks extended)	14'6" (4.42 m)
Overall Width (tracks retracted)	10'2" (3.10 m)
Overall Height	9'6" (2.90 m)
MASS	
Gross Vehicle Mass (Standard Equipment Package)	62,820 LB (28,495 kg)
PERFORMANCE	
Travel Speed	1.6 mph – 2.6 mph (2.6 km/h – 4.2 km/h)
Gradability	53%

CRANE SPECIFICATION

MODEL

6010

CAPACITY

30 ton at 10 feet (27t at 3.0m)

BOOM

3-section full power synchronized telescoping boom. Synchronized telescoping system consists of double acting hydraulic cylinder with load holding valves and extension and retraction cables.

- Retracted Length: 32' 8" (9.9 m)
- Extended Length: 80' 0" (24.4 m)
- Elevating Angles: -1° to 78°
- Boom Head: Five, 15 inch (381 mm) diameter cast nylon sheaves on heavy-duty roller bearings. (3 load bearing and 2 lead in sheaves)
- Extension Time: 70 s
- Elevating Time: 41 s

AUXILIARY BOOM HEAD

Quick reeve, single 15 inch (381 mm) diameter high-strength, cast nylon sheave mounted on a heavy-duty roller bearing.

- Hook Block: 30 ton (27 t) hook block - three 16 inch (406 mm) diameter sheaves mounted on heavy duty roller bearings with swivel hook and safety latch.
- Headache Ball: 7 ton (6.3t) ball includes a swivel hook with a safety latch

COUNTERWEIGHT

11,500 LB (5,220 kg) single piece counterweight can be removed and installed via a pendant attached to the boom

WINCHES

Planetary geared single-speed winch includes a bent axis hydraulic motor, multi-disc internal brake and counterbalance valve. Drum rotation indicator is included (complete winch performance specs on Page 4)

- Main Winch
 - Rope Diameter and Length: 9/16" x 600 ft (14mm x 183m)
 - Single line pull: 11,000 lb (49.9 kN)(first layer)
 - Single line speed: 229 ft/min (69.8 m/min)(4th layer)
- Auxiliary Winch
 - Rope Diameter and Length: 9/16" x 300 ft (14mm x 91m)
 - Single line pull: 12,000 lb (53.4 kN) (first layer)
 - Single line speed: 214 ft/min (65.2 m/min) (at the 4th layer)

TRAVEL

Each side frame contains a pilot controlled, two-speed track drive with hydraulic axial piston motor and parking brake. Travel system provides skid steering and counter rotation.

- Low travel speed: 1.6 mph (2.6km/h)
- High travel speed : 2.6 mph (4.2 km/h)
- Gradeability (unladen): 53%

SWING

Gear motor driving a planetary gear reducer with a shaft mounted pinion, external gear shear ball slew bearing bolted to the superstructure and the carbody allows the superstructure to rotate 360°

- Swing Speed: 0 – 2.2 rpm
- Swing Parking Brake: Spring applied failsafe brake with hydraulic release that is controlled from the operators cab
- Swing Service Brake: Hydraulically applied, controlled through foot actuated pedal
- House Lock System: 2-position, manually pinned

LOAD MOMENT INDICATOR

Standard Rated Capacity Limiter and Anti-Two Block system

- Control function shutdown. Audible and visual warnings
- LCD screen provides a continuous display of working boom length, boom angle, working load radius, tip height, parts-of-line (operator set), machine track configuration, relative load moment, maximum permissible load and actual load.
- Anti-two block weight allows quick reeving of hook block

FRAME

The frame is an all-steel, welded structure, precision machined to accept attachment of the boom and swing components.

OPERATORS CAB

Fully-enclosed, air conditioned all-steel modular cab with lockable swinging door, acoustical lining, anti-slip floor and tinted safety glass.

- Rear view cameras are appropriately located as are three remote control work lights.
- Vent window in the rear of the cab.
- Grab bars and steps are located for easy access to the cab.
- Defroster, heater, circulating fan
- 2-speed windshield wiper, top glass wiper
- Six-way adjustable fabric seat with headrest, seat belt
- Dome light
- Dry-chemical fire extinguisher
- Two-way armrest mounted hydraulic joysticks control swing, boom extend, main winch, and boom hoist. Hydraulic foot pedals control the travel and swing service brake functions.
- Seat and armrest termination switches immediately disable all hydraulic functions as the operator rises from the seat or lifts the left hand armrest.

Dash instrumentation: tachometer, voltmeter, oil pressure gauge, temperature gauge, hour meter and fuel gauge. Indicators are provided for crane level, load moment, drum rotation, air filter restriction, hydraulic oil temperature and filter restriction, engine oil pressure and temperature.

ENGINE

- Make/ Model: Cummins QSB 6.7
- Type: 6 Cylinder, Water cooled, 4 Cycle
- Aspiration: Turbocharged and Charge Air Cooled
- Max. Output: 173 hp (129 kw) @ 2200 RPM
- Max Torque: 589 Lb-ft (799 Nm) @ 1400 RPM
- Piston Disp: 6.7 liter
- Emission Cert: U.S. EPA Tier 3, Euromot Stage IIIA
- Alternator: 100 amp

ELECTRICAL SYSTEM

12 VDC

FUEL SYSTEM

- Capacity: 80 gallon (378 liter)
- Filtration: Inline fuel/water separator and engine mounted fuel filter

SIDE FRAMES

Two welded steel side frames are paired with a track group. The side frames extend and retract hydraulically and are controlled from the cab.

- Track Rollers: Two top and nine bottom sealed rollers on each track frame Idler: Oil filled, self lubricating with spring type tensioner
- Track Shoes: 30 inch (762 mm), 3-bar semi grouser

HYDRAULIC SYSTEM

- Hydraulic Pumps: Two high pressure, variable axial piston pumps with load sense and power limiting control for crane functions. One hydraulic pump for cooling loop
- Directional Valves: Multiple pressure and flow compensated valves with integrated relief valves controlled by hydraulic pilot signals.
- Pump output: 110 gpm (416 l/min) @ 2100 RPM engine speed. 4,800 psi (330 bar) maximum pressure
- Reservoir: 150 gallon (568 liter) capacity, spin-on filler/ breather, sight gauge, cleanout, and sump drain.
- Filtration: 5 micron, full flow tank mounted return filters with electrical clogging indicator. 5 micron pilot oil in-line pressure filter
- Diagnostic Ports: Provided for system, load sense, and pilot pressure

OPTIONAL EQUIPMENT

- Boom Extension: Lattice type, swing away
 - Length: 20 feet (6.1m)
 - Head: Two, 19-inch (483 mm) diameter cast nylon sheaves on heavy-duty roller bearings
 - Max. Lifting Height: 97 ft (29.5 m)
- Boom Jib: Lattice type, swing away, stores along boom extension
 - Length: 20 feet (6.1m)
 - Offset Angles: 15° & 30°
 - Max. Lifting Height: 119 feet (36.3 m)
- Track Shoes: 24 inch (610 mm) 3-bar semi grouser
- Track Shoes: 18 inch (457 mm) 3-bar semi grouser
- Auger Ready Package: Includes hoses, fasteners and stowage bracket assembly mounted to the base section of the boom with a flow capability of 34 gpm (130 l/min)
- Complete Auger Package: Adds a two speed auger motor/gear box and one 60 inch (1.52 m) kelly bar to the Auger Ready Package.
- Tool Circuit: Provides 5 gpm (23 l/min) and 10 gpm (45 l/min) at 2,500 PSI (176 bar) through a 50 foot (15.2m) twin hose reel with quick disconnect fittings to operate open center tools.
- Free Fall Hoists: All winches are available in controlled free fall configurations.
- Cold Weather Packages: Cold weather options are available for operation to -40°C (Consult factory for application support)
- Work Platform: Model WP750 – 36 in x 72 in (0.9m x 1.8m) , all steel, welded, two person platform with maximum capacity of 750 lbs (340 kg).
- Pole Claw: Heavy-duty pole claw with hydraulic clamp and tilt.
- Access walkways
- Radio control package.
- Rotation resistant wire rope.

MAIN HOIST

Planetary geared single-speed winch includes a bent axis, variable displacement hydraulic motor and a multi-disc internal brake. Wire Rope: 600 ft (183 m) 9/16 in (14 mm) 6 x 37 EIPS, IWRC, RRL. Line pulls are not based on wire rope strength. Drum rotation indicator is standard.

Rope Layer	Maximum Line Pull		Full Load Line Speed		Pitch Diameter		Layer		Total	
1	11,000 lb	4,990 kg	198 ft/min	60.4 m/min	11.2 in	284.3 mm	70 ft	21.4 m	70 ft	21.4 m
2	10,000 lb	4,540 kg	212 ft/min	64.6 m/min	12.2 in	309.1 mm	76 ft	23.3 m	147 ft	44.7 m
3	9,100 lb	4,130 kg	221 ft/min	67.4 m/min	13.1 in	333.9 mm	83 ft	25.2 m	229 ft	69.9 m
4	8,400 lb	3,810 kg	229 ft/min	69.8 m/min	14.1 in	358.8 mm	89 ft	27.1 m	318 ft	97.0 m
5	7,800 lb	3,540 kg	244 ft/min	74.4 m/min	15.1 in	383.6 mm	95 ft	28.9 m	413 ft	125.9 m
6	7,300 lb	3,310 kg	247 ft/min	75.3 m/min	16.1 in	408.4 mm	101 ft	30.8 m	514 ft	156.7 m
7	6,800 lb	3,080 kg	256 ft/min	78.0 m/min	17.1 in	433.2 mm	107 ft	32.7 m	621 ft	189.4 m

AUXILIARY HOIST

Planetary geared single-speed winch includes a bent axis, variable displacement hydraulic motor and a multi-disc internal brake. Wire Rope: 300 ft (91 m) 9/16 in (14 mm) 6 x 37 EIPS, IWRC, RRL. Line pulls are not based on wire rope strength. Drum rotation indicator is standard.

Rope Layer	Maximum Line Pull		Full Load Line Speed		Pitch Diameter		Layer		Total	
1	12,000 lb	5,440 kg	182 ft/min	55.5 m/min	10.3 in	261.9 mm	66 ft	20.1 m	66 ft	20.1 m
2	10,800 lb	4,900 kg	198 ft/min	60.4 m/min	11.3 in	286.8 mm	72 ft	22.0 m	138 ft	42.1 m
3	9,800 lb	4,450 kg	205 ft/min	62.5 m/min	12.3 in	311.6 mm	79 ft	23.9 m	217 ft	66.1 m
4	9,000 lb	4,080 kg	214 ft/min	65.2 m/min	13.2 in	336.4 mm	85 ft	25.8 m	302 ft	91.9 m
5	8,300 lb	3,760 kg	228 ft/min	69.5 m/min	14.2 in	361.2 mm	91 ft	27.7 m	393 ft	119.6 m

MACHINE WEIGHTS

STANDARD CRANE WITH 3 SECTION 80 ft 0 in (24.38 m) BOOM, 1 PIECE COUNTERWEIGHT & 30 in (762 mm) TRACK SHOES	59,980 lb	27,210 kg
Crane Less Counterweight	48,480 lb	21,990 kg
Counterweight	11,500 lb	5,220 kg

OPTIONAL EQUIPMENT

20 ft (6.10 m) Lattice Extension	1,200 lb	544 kg
20 ft (6.10 m) Jib (connects to head of Lattice Extension ONLY)	700 lb	318 kg
Auxiliary Nose Sheave	150 lb	68 kg
Auxiliary Winch with Standard Rope	607 lb	275 kg
7 ton (6 mt) Headache Ball	162 lb	74 kg
30 ton (27 mt) Hook Block	760 lb	345 kg
Auger Ready Package	440 lb	200 kg
Complete Auger Package	1,520 lb	690 kg
60 in (1.52 m) Auger Kelly Bar	120 lb	54 kg
72 in (1.83 m) Auger Kelly Bar	140 lb	64 kg

* Deduction from Standard Crane Weight

DIMENSIONS

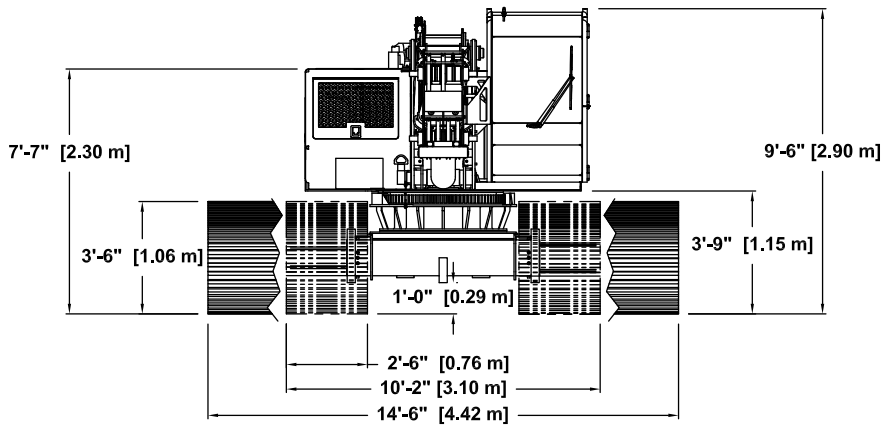
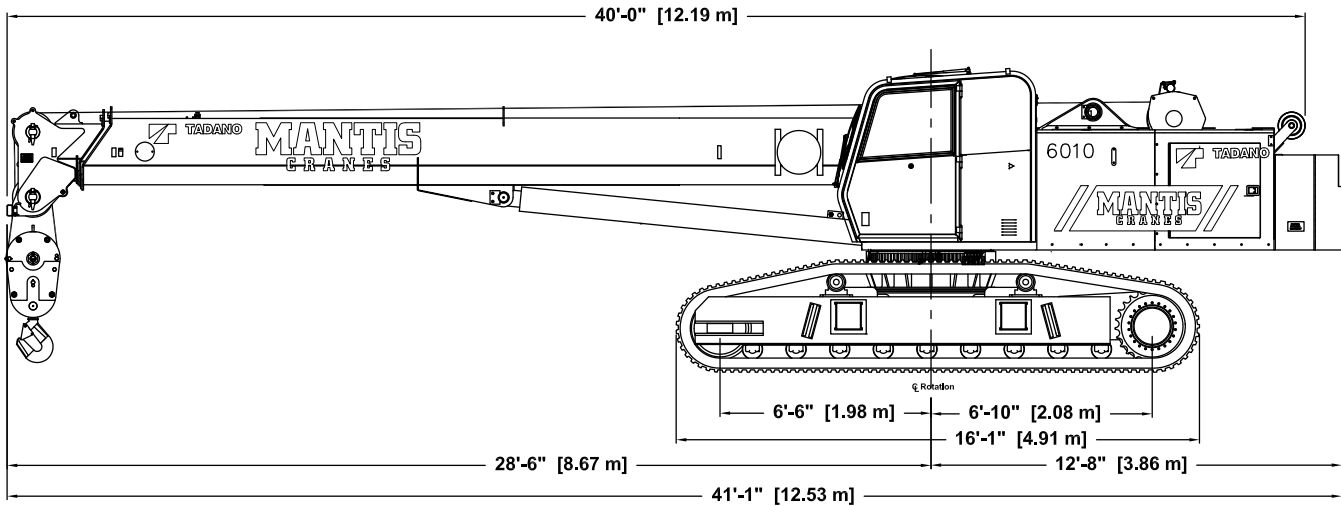

WIDTHS, WEIGHTS, AND GROUND PRESSURES*

Shoe Width	Overall Width		Area	Ground Pressure	Working Weight
	Retracted	Extended			
18 in (457 mm)	8 ft 6 in (2.59 m)	13 ft 6 in (4.11 m)	5,760 in ² (3.72 m ²)	10.5 psi (0.74 kg/cm ²)	60,505 lb (27,445 kg)
24 in (609 mm)	9 ft 8 in (2.95 m)	14 ft 0 in (4.27 m)	7,680 in ² (4.95 m ²)	8.0 psi (0.56 kg/cm ²)	61,665 lb (27,971 kg)
30 in (762 mm)	10 ft 2 in (3.10 m)	14 ft 6 in (4.42 m)	9,600 in ² (6.19 m ²)	6.5 psi (0.46 kg/cm ²)	62,820 lb (28,495 kg)

*Crane equipped with: 80 ft boom, extension, jib, 30 ton hook block, and 7 ton headache ball

80 FT MAIN BOOM, 20 FT EXTENSION & 20 FT JIB

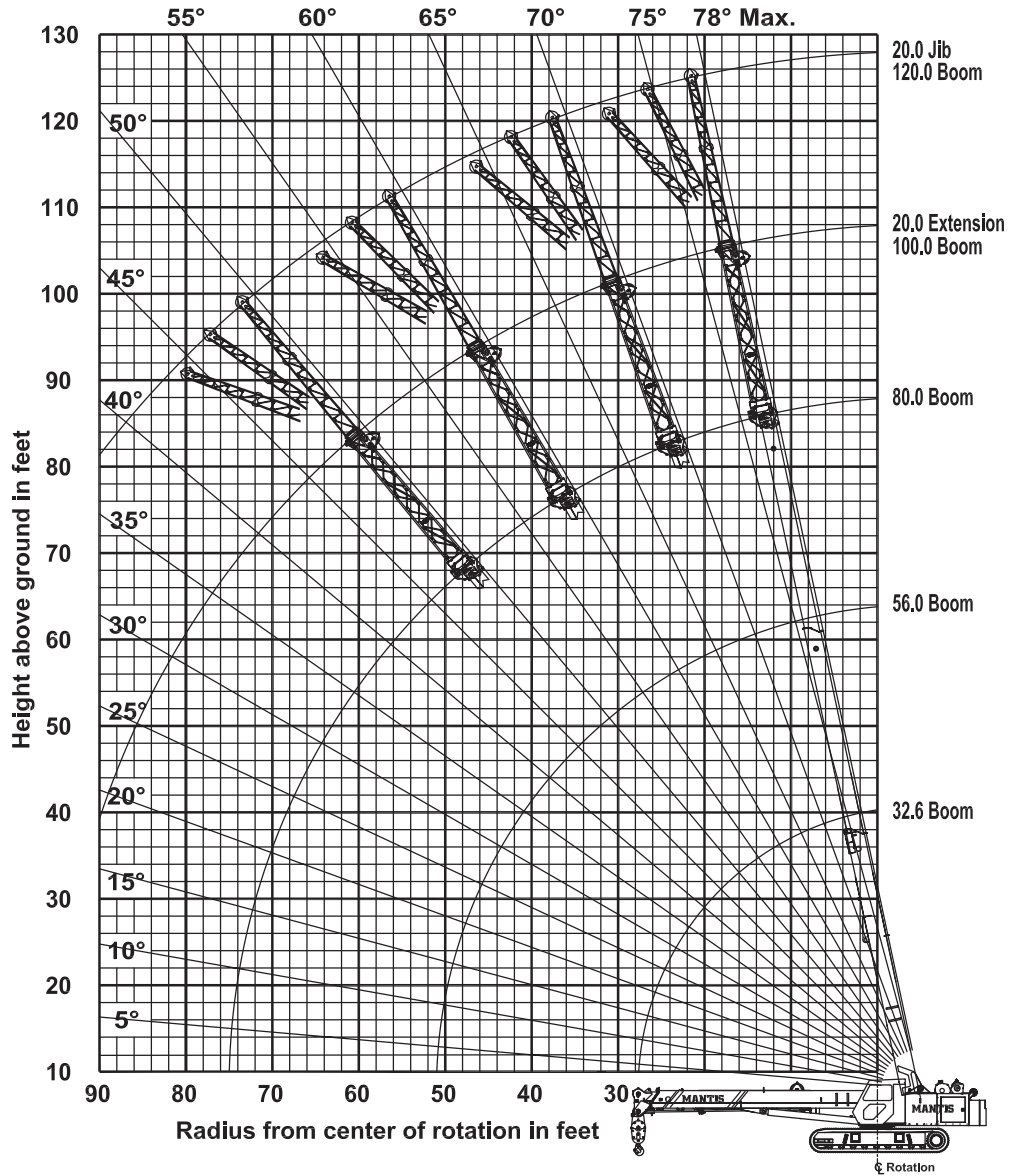
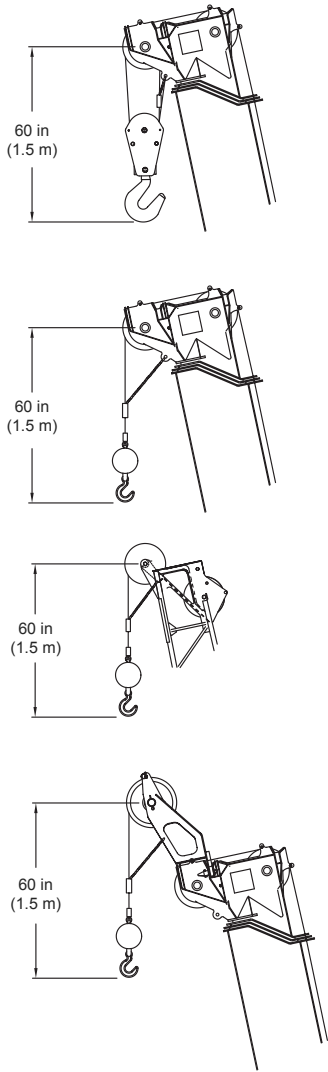

CAUTION: THESE CHART VALUES ARE ONLY A GUIDE AND MUST NOT BE USED TO OPERATE THE CRANE.
USE ONLY THE IN CAB LOAD CHARTS AND OPERATORS MANUAL FURNISHED WITH THE CRANE.

LOAD CHARTS

360 DEGREE RATING - LOADS IN lb x 1000

MAIN BOOM with TRACKS FULLY EXTENDED															
11,500 lb COUNTERWEIGHT								ZERO COUNTERWEIGHT							
RADIUS (ft)	MAIN BOOM LENGTH (ft)							MAIN BOOM LENGTH (ft)							RADIUS (ft)
	33.0	41.0	48.0	56.0	64.0	72.0	80.0	33.0	41.0	48.0	56.0	64.0	72.0	80.0	
8	60.0	48.0	47.6*					60.0	48.0	47.6*					8
	71.8°	75.5°	77.9°					71.8°	75.5°	77.9°					
10	60.0	48.0	47.6	44.9*				53.0	48.0	47.6	44.9*				10
	67.9°	72.5°	75.5°	77.6°				67.9°	72.5°	75.5°	77.6°				
12	56.0	48.0	47.6	40.5	34.2*			35.4	35.7	35.9	36.0	34.2*			12
	63.9°	69.4°	73.0°	75.4°	77.3°			63.9°	69.4°	73.0°	75.4°	77.3°			
15	38.5	38.7	38.9	35.4	29.8	26.0	22.8*	23.0	25.3	23.5	23.6	23.6	23.7	22.8*	15
	57.5°	64.7°	69.1°	72.2°	74.5°	76.2°	77.6°	57.5°	64.7°	69.1°	72.2°	74.5°	76.2°	77.6°	
20	24.0	24.2	24.3	24.4	24.0	21.3	18.7	13.9	14.1	14.2	14.3	14.4	14.4	14.5	20
	45.5°	56.2°	62.5°	66.7°	69.7°	72.1°	73.9°	45.5°	56.2°	62.5°	66.7°	69.7°	72.1°	73.9°	
25	16.9	17.2	17.3	17.3	17.4	17.0	15.8	9.4	9.6	9.8	9.9	9.9	10.0	10.0	25
	29.0°	46.6°	55.3°	60.8°	64.8°	67.8°	70.1°	29.0°	46.6°	55.3°	60.8°	64.8°	67.8°	70.1°	
30		13.0	13.1	13.2	13.2	13.3	13.0		7.0	7.1	7.2	7.3	7.3	7.3	30
		34.7°	47.3°	54.6°	59.6°	63.3°	66.2°		34.7°	47.3°	54.6°	59.6°	63.3°	66.2°	
35		10.2	10.3	10.4	10.5	10.5	10.5		5.2	5.4	5.5	5.5	5.6	5.6	35
		14.5°	38.0°	47.8°	54.1°	58.7°	62.1°		14.5°	38.0°	47.8°	54.1°	58.7°	62.1°	
40			8.4	8.5	8.5	8.5	8.6			4.1	4.2	4.3	4.3	4.4	40
			25.5°	40.1°	48.2°	53.8°	57.9°			25.5°	40.1°	48.2°	53.8°	57.9°	
45				7.0	7.1	7.1	7.1				3.3	3.4	3.4	3.4	45
				30.6°	41.6°	48.5°	53.4°				30.6°	41.6°	48.5°	53.4°	
50				5.9	5.9	6.0	6.0				2.6	2.7	2.7	2.7	50
				15.8°	33.8°	42.7°	48.7°				15.8°	33.8°	42.7°	48.7°	
55					5.0	5.1	5.1					2.1	2.1	2.1	55
					23.7°	36.1°	43.5°					23.7°	36.1°	43.5°	
60						4.3	4.4						1.6	1.7	60
						28.1°	37.8°						28.1°	37.8°	
65						3.7	3.7						1.3	1.3	65
						16.4°	31.1°						16.4°	31.1°	
70							3.2							1.0	70
							22.6°							22.6°	
75							2.8							0.7	75
							4.2°							4.2°	

* Capacity based on maximum obtainable boom angle.

° Boom angles are stated in degrees.

NOTE: Capacities appearing above the bold line are based on structural strength; tipping should not be relied upon as a capacity limitation.
Capacities appearing below the bold line are based on stability and do not exceed 75% of tipping.

CAUTION: THESE CHART VALUES ARE ONLY A GUIDE AND MUST NOT BE USED TO OPERATE THE CRANE.
USE ONLY THE IN CAB LOAD CHARTS AND OPERATORS MANUAL FURNISHED WITH THE CRANE.

LOAD CHARTS

360 DEGREE RATING - LOADS IN lb x 1000

MAIN BOOM with TRACKS FULLY RETRACTED			
11,500 lb COUNTERWEIGHT			
RADIUS (ft)	MAIN BOOM LENGTH (ft)		RADIUS (ft)
	33.0	Over 33	
8	60.0	47.6	8
10	49.6	44.9	10
12	36.3	34.2	12
14	25.9	25.9	14
16	21.6	21.6	16
18	17.9	17.9	18
20	15.0	15.0	20
22	12.7	12.7	22
24	11.0	11.0	24
26	9.6	9.6	26
28	8.5	8.5	28
30	7.7	7.7	30
32	7.0	7.0	32
34	6.3	6.3	34
36	5.8	5.8	36
38	5.4	5.4	38
40	5.0	5.0	40
42	4.6	4.6	42
44	4.3	4.3	44
46	4.0	4.0	46
48	3.7	3.7	48
50	3.4	3.4	50
52	3.2	3.2	52
54	2.9	2.9	54
56	2.7	2.7	56
58	2.5	2.5	58
60	2.3	2.3	60
62	2.1	2.1	62
64	1.9	1.9	64
66	1.7	1.7	66
68	1.6	1.6	68
70	1.4	1.4	70

20' EXTENSION & 20' JIB with TRACKS FULLY EXTENDED						
11,500 lb COUNTERWEIGHT						
20' EXTENSION			20' JIB			
Boom Angle	Total Boom Length (ft)		Jib Offset Angles			Boom Angle
	53.0 to 91.9	92.0 to ?	0°	15°	30°	
78°	12.4	12.4	6.6	4.0	2.2	78°
75°	10.5	10.5	6.3	4.0	2.1	75°
72°	9.3	9.3	5.6	3.5	2.0	72°
70°	8.6	8.6	5.1	3.2	1.9	70°
68°	8.0	8.0	4.6	3.0	1.8	68°
65°	7.2	6.8	4.2	2.8	1.8	65°
62°	6.6	5.7	3.9	2.6	1.7	62°
60°	6.2	4.9	3.5	2.4	1.7	60°
58°	5.9	4.3	3.2	1.9	1.4	58°
55°	5.5	3.7	2.6	1.3	1.0	55°
52°	5.2	3.2	2.0	0.6	0.4	52°
50°	5.0	2.9	1.5	0.3	0.2	50°
48°	4.4	2.6				48°
45°	4.2	2.3				45°

ZERO DEGREE BOOM ANGLE			
MAXIMUM CAPACITY			
with TRACKS FULLY EXTENDED			
11,500 lb COUNTERWEIGHT			
BOOM LENGTH (ft)	RADIUS (ft)	LOAD (lbs) (x 1000)	BOOM LENGTH (ft)
32.7	27.7	15.4	32.7
40.6	35.6	10.0	40.6
48.4	43.4	7.7	48.4
56.3	51.3	5.7	56.3
64.3	59.2	4.6	64.3
71.1	67.1	3.5	71.1
80.0	75.0	2.8	80.0

WEIGHT REDUCTIONS	
LOAD HANDLING DEVICES	
HOOKBLOCK: 30 Ton - 3 Sheave	760 lbs
OVERHAUL BALL: 7 Ton w/Swivel	162 lbs
OPTIONAL HANDLING DEVICES	
20 ft. Extension - Stowed**	320 lbs
20 ft. Extension - Erected**	1,600 lbs
20 ft. Ext. and 20 ft. Jib - Stowed**	450 lbs
20 ft. Ext. and 20 ft. Jib - Erected**	3,100 lbs
Auxillary Nose Sheave**	160 lbs

** Reduction of main boom capacities.

NOTE: Capacities appearing above the bold line are based on structural strength; tipping should not be relied upon as a capacity limitation. Capacities appearing below the bold line are based on stability and do not exceed 75% of tipping.

CAUTION: THESE CHART VALUES ARE ONLY A GUIDE AND MUST NOT BE USED TO OPERATE THE CRANE. USE ONLY THE IN CAB LOAD CHARTS AND OPERATORS MANUAL FURNISHED WITH THE CRANE.

LOAD CHARTS

360 DEGREE RATING - LOADS IN lb x 1000

AUXILIARY NOSE SHEAVE with TRACKS FULLY EXTENDED															
11,500 lb COUNTERWEIGHT								ZERO COUNTERWEIGHT							
RADIUS (ft)	MAIN BOOM LENGTH (ft)							MAIN BOOM LENGTH (ft)							RADIUS (ft)
	33.0	41.0	48.0	56.0	64.0	72.0	80.0	33.0	41.0	48.0	56.0	64.0	72.0	80.0	
8	6.0	6.0	6.0					6.0	6.0	6.0					8
	71.8°	75.5°	77.9°					71.8°	75.5°	77.9°					
10	6.0	6.0	6.0	6.0				6.0	6.0	6.0	6.0				10
	67.9°	72.5°	75.5°	77.6°				67.9°	72.5°	75.5°	77.6°				
12	6.0	6.0	6.0	6.0	6.0			6.0	6.0	6.0	6.0	6.0			12
	63.9°	69.4°	73.0°	75.4°	77.3°			63.9°	69.4°	73.0°	75.4°	77.3°			
15	6.0	6.0	6.0	6.0	6.0	6.0	6.0	6.0	6.0	6.0	6.0	6.0	6.0	6.0	15
	57.5°	64.7°	69.1°	72.2°	74.5°	76.2°	77.6°	57.5°	64.7°	69.1°	72.2°	74.5°	76.2°	77.6°	
20	6.0	6.0	6.0	6.0	6.0	6.0	6.0	6.0	6.0	6.0	6.0	6.0	6.0	6.0	20
	45.5°	56.2°	62.5°	66.7°	69.7°	72.1°	73.9°	45.5°	56.2°	62.5°	66.7°	69.7°	72.1°	73.9°	
25	6.0	6.0	6.0	6.0	6.0	6.0	6.0	6.0	6.0	6.0	6.0	6.0	6.0	6.0	25
	29.0°	46.6°	55.3°	60.8°	64.8°	67.8°	70.1°	29.0°	46.6°	55.3°	60.8°	64.8°	67.8°	70.1°	
30		6.0	6.0	6.0	6.0	6.0	6.0		6.0	6.0	6.0	6.0	6.0	6.0	30
		34.7°	47.3°	54.6°	59.6°	63.3°	66.2°		34.7°	47.3°	54.6°	59.6°	63.3°	66.2°	
35		6.0	6.0	6.0	6.0	6.0	6.0		5.2	5.4	5.5	5.5	5.6	5.6	35
		14.5°	38.0°	47.8°	54.1°	58.7°	62.1°		14.5°	38.0°	47.8°	54.1°	58.7°	62.1°	
40			6.0	6.0	6.0	6.0	6.0			4.1	4.2	4.3	4.3	4.4	40
			25.5°	40.1°	48.2°	53.8°	57.9°			25.5°	40.1°	48.2°	53.8°	57.9°	
45				6.0	6.0	6.0	6.0				3.3	3.4	3.4	3.4	45
				30.6°	41.6°	48.5°	53.4°				30.6°	41.6°	48.5°	53.4°	
50				5.4	5.5	6.0	6.0				2.6	2.7	2.7	2.7	50
				15.8°	33.8°	42.7°	48.7°				15.8°	33.8°	42.7°	48.7°	
55					4.6	4.7	4.7					2.1	2.1	2.1	55
					23.7°	36.1°	43.5°					23.7°	36.1°	43.5°	
60						4.0	4.0						1.6	1.7	60
						28.1°	37.8°						28.1°	37.8°	
65						3.4	3.4						1.3	1.3	65
						16.4°	31.1°						16.4°	31.1°	
70							2.9							1.0	70
							22.6°							22.6°	
75							2.5							0.7	75
							4.2°							4.2°	

° Boom angles are stated in degrees.

NOTE: Capacities appearing above the bold line are based on structural strength; tipping should not be relied upon as a capacity limitation. Capacities appearing below the bold line are based on stability and do not exceed 75% of tipping.

CAUTION: THESE CHART VALUES ARE ONLY A GUIDE AND MUST NOT BE USED TO OPERATE THE CRANE. USE ONLY THE IN CAB LOAD CHARTS AND OPERATORS MANUAL FURNISHED WITH THE CRANE.

LOAD CHARTS

WP-750 WORK PLATFORM
Installed on MANTIS MODEL 6010
as originally manufactured and equipped by Tadano Mantis Corporation

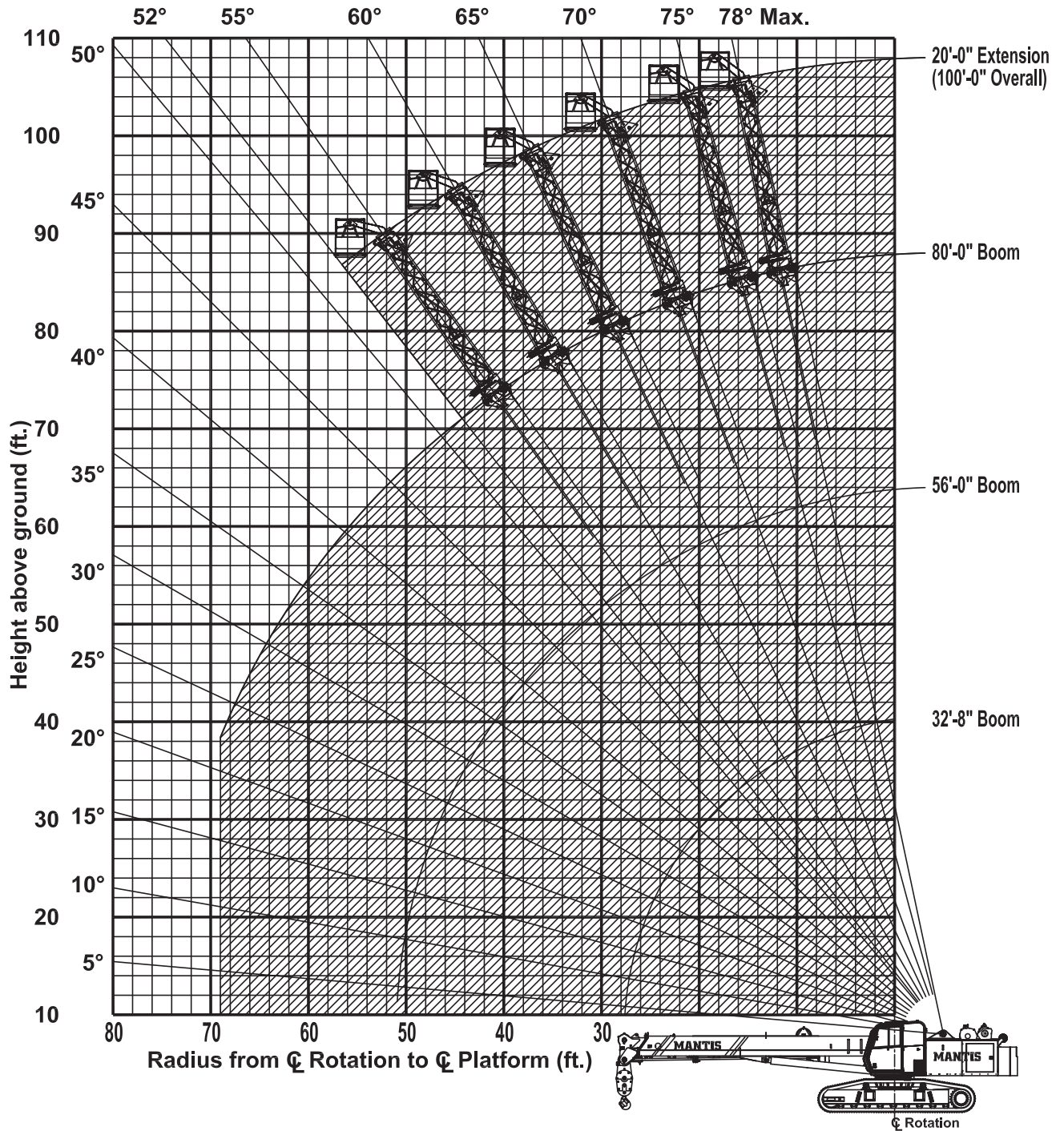

Limits of operation: Maximum load capacity = 750 lb Maximum radius when mounted on main boom = 68 ft

CAUTION: THESE CHART VALUES ARE ONLY A GUIDE AND MUST NOT BE USED TO OPERATE THE CRANE.
 USE ONLY THE IN CAB LOAD CHARTS AND OPERATORS MANUAL FURNISHED WITH THE CRANE.

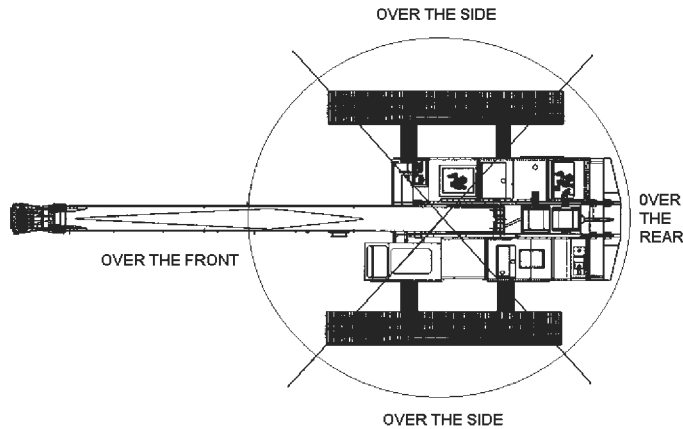

MANTIS MODEL 6010				
WIRE ROPE LINE PULL CAPACITIES				
PARTS OF LINE	MAIN WINCH (pounds)	AUX WINCH (pounds)	PARTS OF LINE	MAIN WINCH (pounds)
1	9,600	9,600	5	48,000
2	19,200	19,200	6	57,600
3	28,800	N/A	7	67,200
4	38,400	N/A		
9/16 inch diameter wire rope, 6 x 37 Class, EIP, IWRC				

PLEASE READ, UNDERSTAND, AND FOLLOW THE MANUALS FURNISHED WITH THE CRANE (OPERATORS AND SAFETY) AS WELL AS THE CAPACITY LIMITATIONS AND GENERAL CONDITIONS LISTED BELOW PRIOR TO OPERATION OF THE CRANE. FAILURE TO DO SO MAY RESULT IN AN ACCIDENT.

This **MANTIS CRANE** as manufactured by Tadano Mantis Corporation meets the requirements of **ASME B30.5**. Structure and stability have been tested in accordance with **SAE J1063** and **SAE J765**, respectively. Lifting capacities as determined by boom length, angle or radius, apply only to machines as originally equipped by manufacturer and in a properly maintained condition. Capacities given are maximum covered by the manufacturer's warranty and are based on a freely suspended load with **NO** allowance for factors as out-of-level operation, supporting surface conditions, hazardous surroundings, experience of personnel, etc. The operator shall establish practical working loads based on prevailing operating conditions, such as, but not limited to the above.

When making lifts where capacities may be within a zone limited by structural strength, the operator shall determine that the weight of the load is known within plus or minus (+/-) ten percent (10%) before making lift. **DO NOT** lift load or extend boom without counterweight in place. Deductions from rated capacities must be made for the weight of the hook block, hook/ball, slings, spreader bar, or other suspended equipment.

Side pull on boom is extremely dangerous and must be avoided.

DO NOT exceed manufacturer's maximum specified reeving.

DO NOT use this chart if wind speed exceeds 20 mph. Consult the manufacturer for specialized load ratings.

Load radius is defined as the horizontal distance from the axis of rotation (with no load) to the center of the lifting device after load is applied. Boom angle is the included angle between the longitudinal axis of the boom base section and the Horizontal axis, after lifting load. The boom angle before lifting should be slightly greater than desired to account for boom deflection.

Boom angle/boom length relationships given are an approximation of the resulted load radius, which should be an accurate measurement. Boom height dimensions are measured from ground to center of lower boom head sheave.

It is permissible to attempt to telescope boom with a load within the limits of rated capacities. However, boom angle system hydraulic pressure, and/or boom lubrication may affect operation.

It is permissible to travel with loads within the rated capacity of the crane. Travel speeds should be greatly reduced to reflect terrain limitations and minimize dynamic loads applied to the crane structure.

CAUTION: THESE CHART VALUES ARE ONLY A GUIDE AND MUST NOT BE USED TO OPERATE THE CRANE.
USE ONLY THE IN CAB LOAD CHARTS AND OPERATORS MANUAL FURNISHED WITH THE CRANE.

TADANO MANTIS CORPORATION

1705 Columbia Avenue • Franklin, TN 37064 USA • Toll-Free: 1-800-272-3325 • Fax: 615-790-6803 • mantiscranes.com