

IC-400-B **Industrial Crane**

Broderson's long reach 25 US ton capacity carry deck crane, the IC-400 provides heavy duty capacity to take care of all your long reach light and heavy duty lifting needs.

Capacity

50,000 lbs. (22,700 kg)

Sheave Height

99' (30.18 m)

Horizontal Reach

90' (27.43 m)

Height

9' 11" (2.96 m)

Width

8' 6" (2.59 m)



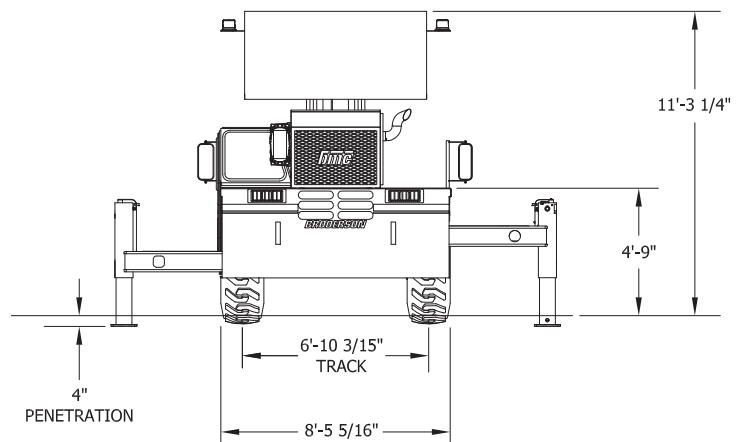
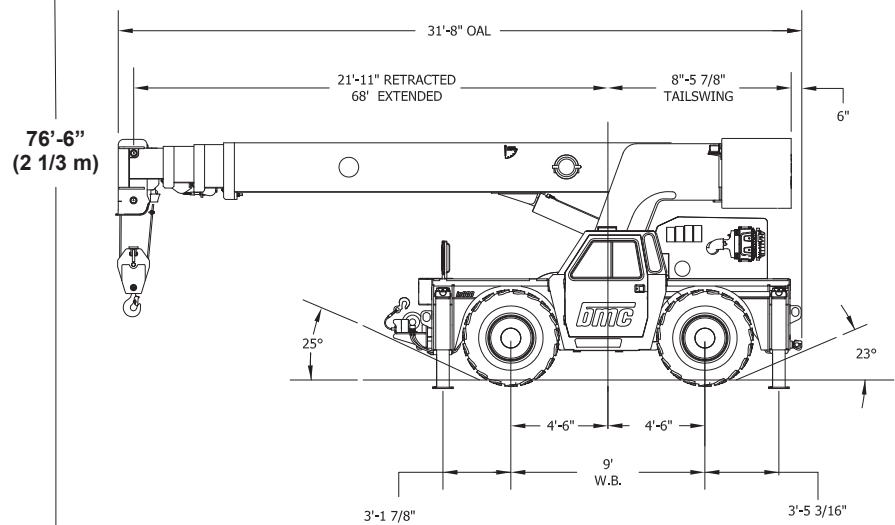
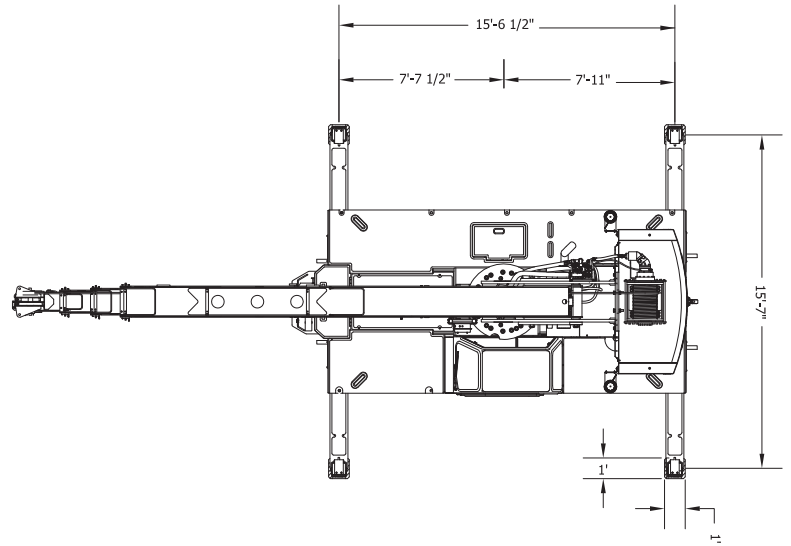
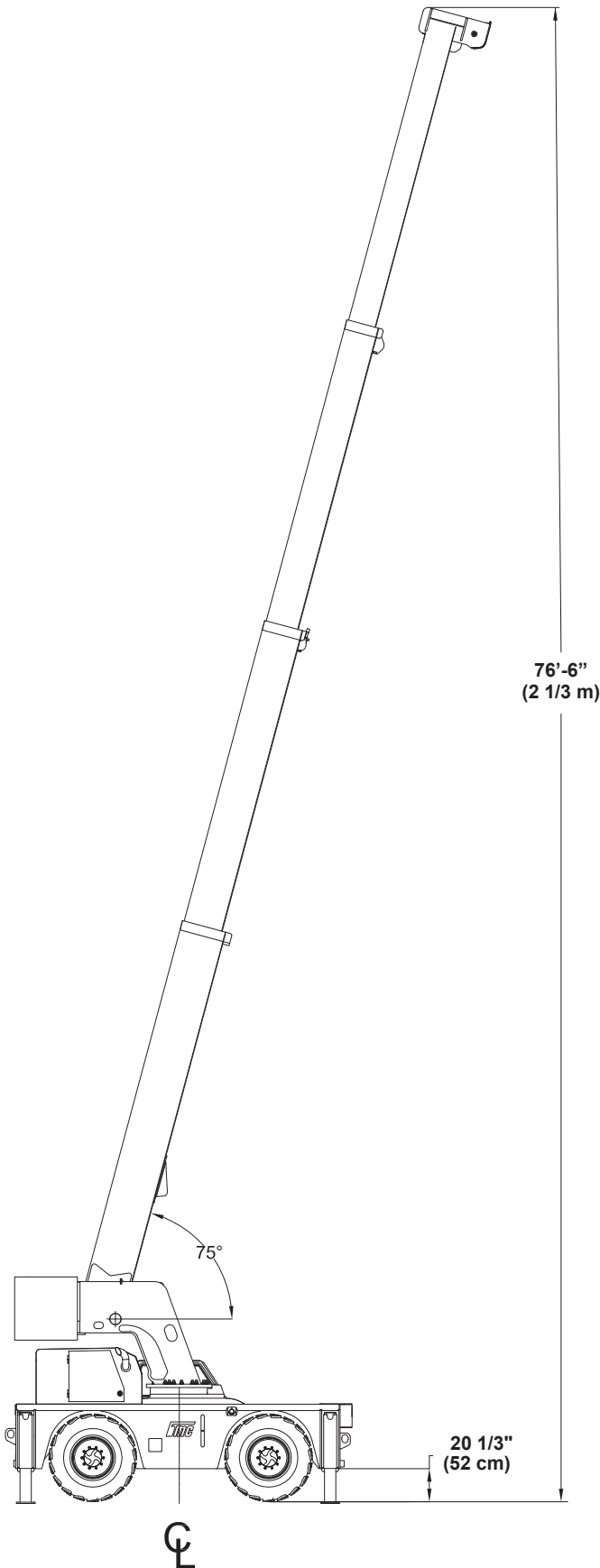

IC-400-B

GENERAL SPECIFICATIONS



GENERAL

	ROTATION	ELEVATION	EXTENSION
Boom Movement	Continuous	0° to 75°	46'6" (14.17m)
Weight Total	54,900 lbs. (24,900 kg.)		
Front Axle	29,400 lbs. (13,330 kg.)		
Rear Axle	25,500 lbs. (11,570 kg.)		
Gradeability	70% (34°)		
Turning Radius	15' 10" (4.83 m)		

ENGINE

Make	Cummins
Model	QSB4.5 (US EPA Tier 4F)
Type	Turbocharged-Diesel, charge air cooled
Cylinder	4
Displacement	4.5 L
HP at Gov. Speed	163 HP
Fuel Tank Capacity	80 gal.

TRANSMISSION

POWERSHIFT TRANSMISSION with 6-speeds (2 range, 3 speeds/range) forward and reverse. Oil cooler and filter. Operator interface to shift and disconnect front axle for 2-wheel drive operation.

FORWARD GEAR RATIOS & SPEEDS

GEAR	RATIO	SPEED (MPH)
1st	8.93	2.1 (3.4 km/h)
2nd	4.63	4.0 (6.4 km/h)
3rd	1.70	10.5 (16.9 km/h)
4th	3.75	4.9 (7.9 km/h)
5th	1.94	9.2 (14.8 km/h)
6th	0.71	23.6 (38 km/h)

REVERSE GEAR RATIOS & SPEEDS

GEAR	RATIO	SPEED (MPH)
1st	8.93	2.7 (4.3 km/h)
2nd	4.63	6.3 (10.1 km/h)
3rd	1.70	15 (25.4 km/h)
4th	3.75	4.9 (7.9 km/h)
5th	1.94	9.2 (14.8 km/h)
6th	0.71	23.6 (38 km/h)

AXLES

FRONT

Planetary drive/steer front axle with 19:333 to 1.0 ratio. Differential equipped with "limited slip" feature. Front axle mounted rigidly to frame.

REAR

Planetary drive/steer axle with 19:333 to 1.0 ratio. Rear axle is rigid mounted. Axle has a 30% limited slip-differential.

STEERING

Hydraulic steering unit with one cylinder attached to each axle. Allows limited steering when engine is not running. A switch on the control panel is used to select rear-wheel steering, 4-wheel steering or crab steering. Electronic sensors and control box automatically align the steering after a new mode is selected.

BRAKES

Service: 4-wheel hydraulic internal wet-disc brakes.

Parking: Internal wet disc, spring applied and hydraulically released and integral to the rear axle.

TIRES

Standard:

17.5 x 25, 20-ply rating, mud lug.

CHASSIS

CARGO DECK

Total Deck Area: 74 sq. ft. (6.94 m²) of deck area. 25,000 lbs. (11,340 kg) capacity on deck when load is centered over or between axles. Five deck stakes are provided along edge of deck for 1" (25mm) pipe stakes. Stakes furnished. Cargo decks have skid resistant coating.

HEADLIGHT AND TAILLIGHT GRILLES

Steel protective grilles for headlights and taillights. Easily removable for replacing bulbs.

OUTRIGGERS

Four hydraulic out and down outriggers of box beam construction. Hydraulic cylinders are equipped with direct-connected holding valves. Outrigger pad dimensions: 11.5" (29 cm) x 11.5" (29 cm).

ACCESSORY STORAGE BOX

One side deck compartment and one front deck compartment.

LIFTING RINGS

Lifting rings at each corner of cargo deck so sling can be attached for lifting crane. Rings hang below surface when not in use.

OPERATOR COMPARTMENT

Provides one-position access to all chassis and crane functions. Includes adjustable operator's seat and seat belt, arm rests, and tilt steering column. Also includes access point to J1939 CAN Bus system.

ALL WEATHER CAB

Consists of rigid mounted canopy section and removable hinged door with safety glass. Rugged canopy structure with laminated glass front and top. Door is equipped with a keyed lock to protect operator's station. Includes defroster fan, dome light, heater with 2-speed fan and 12V electric windshield wiper and windshield washer, 12 volt power outlet. Emergency exit through rear window.

CLIMATE CONTROL/OPERATOR COMFORT

Integrated heater and air conditioning standard.

ELECTRONIC CONTROLS

Dual, two-axis joysticks provide control of boom motions and hoist. Triggers prevent inadvertent boom motion. Arming command push-button on panel, along with RH joystick, enable or disable the functions of joysticks in conjunction with seat switch or dead man switch. Push-button switch on LH panel separates boom function from outrigger functions.

ELECTRICAL (12-VOLT SYSTEM)

LIGHTING PACKAGE

One pair headlights with high and low beams; tail, brake and turn signal lights and back-up lights in rear; turn signals and emergency flasher switch at operator's station.

INSTRUMENT PACKAGE

Located on the dashboard at the operator's station is the key pad for outrigger operation, an engine display unit, rocker switches for various functions, and indicator lights. Included with the engine display are simulated gages displaying real-time values for engine RPM, battery voltage, engine hours, fuel level, oil pressure, and coolant temperature. Additional warning lamps monitor vitals like engine status, low fuel, low battery, low oil pressure, and high hydraulic fluid temperature.

BACK-UP ALARM

Provides pulsating sound from 102 dB alarm when transmission is in reverse.

OUTRIGGER ALARM SYSTEM

Two-tone alarm is activated when "jack down" or "beam out" controls are operated.

EMERGENCY STOP SWITCH

A two-position push button switch located on the top left-hand of the dash panel. Designed to stop the engine and shut down the hydraulic system.

HYDRAULIC

TWO PISTON PUMPS mounted on and driven by the main transmission, delivers a combine flow of 103 GPM (390 L / min) at 4,000 psi (275.8 bar) and 2600 engine rpm speed. System protected by relief valves, suction-line strainers, and a 150 gpm, 10-micron return-line filter.

Four-section, high-strength steel construction, with lubricant-filled bearing pads. Doubleacting hydraulic cylinders, equipped with a holding valve, extend and retract the second and third boom sections. Double runs of high strength leaf chain extend & retract the fourth section. Boom angle indicator included on left side of boom. Single hydraulic cylinder controls boom elevation. Lift cylinder equipped with mounted holding valves.

BOOM ROTATION

Heavy-duty ball bearing rotation gear with external teeth. Rotation is powered by hydraulic motor and worm gear drive.

BOOM HOIST

Turret Mounted/Hydraulic Powered Bare Drum Line Pull: 13,800 lbs. (6,520 kg) Wire Rope: 425 ft. (130 m) of 5/8" (16 mm) dia. Line Speed: sheave block for four-part line requirement. Downhaul weight and hook included — standard..

ANTI-TWO-BLOCK DEVICE

Prevents damage to hoist rope and/or crane components from pulling load hook against tip.

BRODERSON RATED CAPACITY LIMITER

Warns operator of impending overload with audible and visual signals, stopping boom functions that will cause overloads.

FOUR-PART-LINE SHEAVE BLOCK

Double-sheave block for 4-part-line requirements. Downhaul weight and hook included as standard.

BOOM ASSEMBLY

CONSULT THE IC-400-B ENGINEERING SPEC FOR ADDITIONAL INFORMATION.

Main Features

RATED CAPACITY LIMITER
Broderson RCL Standard

CAPACITY ON OUTRIGGERS
50,000 lbs. (22,700 kg)

PICK AND CARRY CAPACITY
25,000 lbs. (11,340 kg)

HEIGHT
11'3" (3.43 m)

WIDTH
8' 6" (2.59 m)

BOOM ROTATION
360°

SHEAVE HEIGHT
up to 99' (30.18 m)

HORIZONTAL REACH
up to 90' (27.03 m)

FOUR-WHEEL STEER
Standard

FOUR-WHEEL DRIVE
Standard

POWERSHIFT TRANSMISSION
Standard

TIGHT TURNING RADIUS

**FULLY ELECTRONIC CONTROLS
FOR SMOOTH, PRECISE
OPERATIONS**

**INDEPENDENT OUTRIGGER
CONTROLS**
3 Outrigger widths

Options

TIRE OPTIONS
Spare tire and wheel

CHASSIS OPTIONS

Auxiliary Winch

Planetary gear winch mounted beneath chassis frame, with push-button control in operator's console.

Pintle Hook

Rear and/or front

Rearview Mirrors

One mounted on right-hand deck stake and one mounted on left-hand deck stake.

OPERATOR COMPARTMENT

Floor Mat

Vinyl mat with foam backing.

Sun Visor

Adjustable sun visor for reducing glare mounted in roof of cab.

Noise Reduction Kit

Includes floor mat, control valve cover and side panels of foam backed vinyl for noise reduction.

ELECTRICAL OPTIONS

Strobe Lights

Yellow LED strobe light mounted on each side of turret weight box

Camera System

4-camera video system to assist operator with hard-to-see viewpoints

Boom Work Lights

One LED worklight mounted to boom to light boom tip, and one work light mounted to turret to light ground under boom tip.

RCL Light Bar

3 color light bar for external indication of load status

BOOM ATTACHMENTS:

Boom Extension

20 ft. (6.1 m) offset. Boom stowable. Boom extension is offsettable to 3 different positions; 0 degree (in-line), 15 degree and 30 degree offset. Maximum Sheave height is 99'3", and maximum reach is 90'.

Broderson Cranes are manufactured to ISO 9001:2015 certified standards and have a market leading reputation for quality and reliability. Broderson Cranes are engineered for operating efficiency and are easy to operate and maintain.

An extensive network of full-service dealers offer parts and service support by factory-trained technicians.

For additional options or special equipment not listed, please consult your dealer salesperson or contact Broderson Manufacturing Corp.

BRODERSON®
Manufacturing Corp.
14741 West 106th Street
Lenexa, KS 66215 USA

(913) 888-0606
www.BMCcranes.com

Dimensions and values
shown are for reference
purposes only.
Specifications subject
to change.

